

CONTENTS OF MOTOR PACK PROVIDED BY HYDROS

- 1 BLDC MOTOR, 36V/1400W
- 1 NACA aluminium leg
- 2 M6 rods to fix the motor

2x M6 rods, length 1m

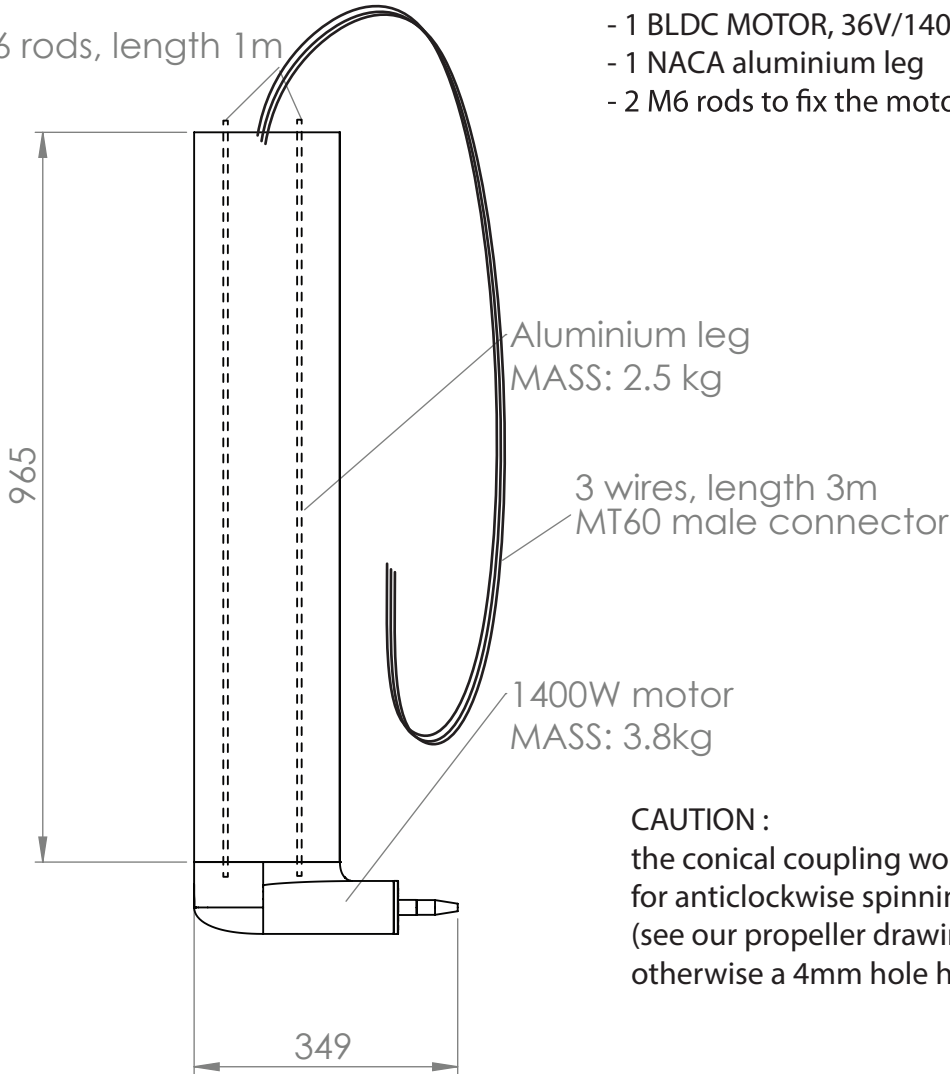

CAUTION :

the conical coupling works only for anticlockwise spinning propeller in forward (see our propeller drawing for reference) otherwise a 4mm hole has been added on the shaft

CONICAL SHAFT DETAIL :

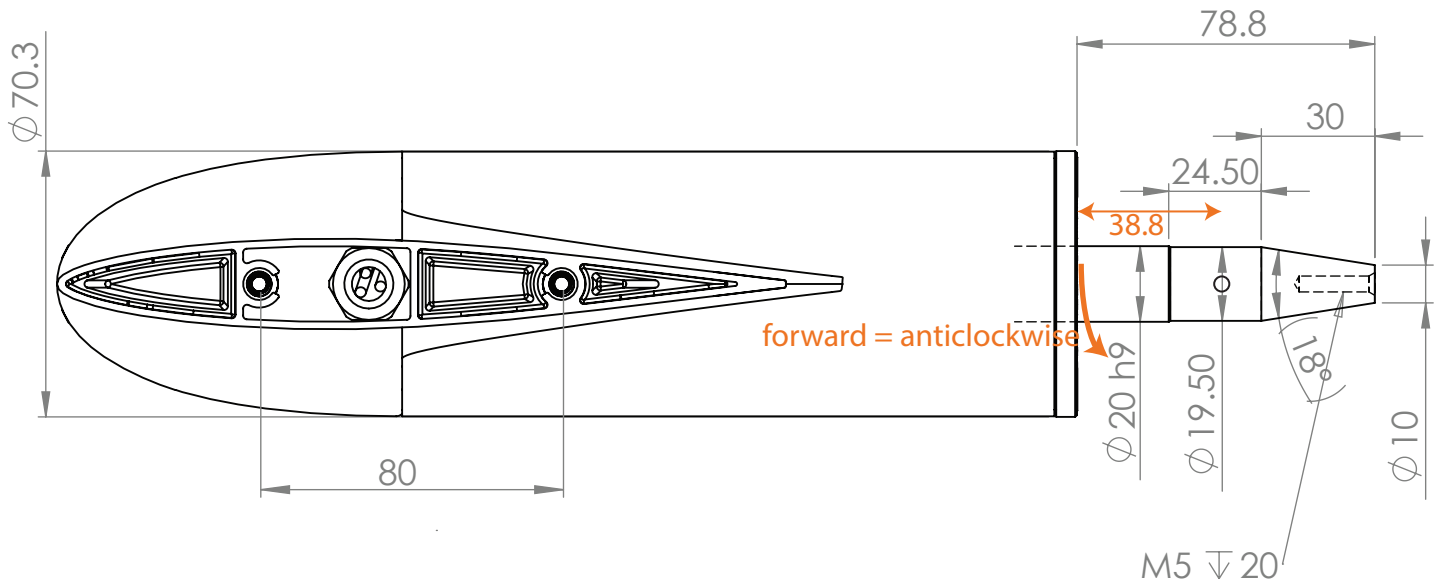

|        |  |
|--------|--|
| DATE:  | 01/04/2017   |
| TITRE: | 1400W/36V MOTOR PACK<br>for HYDROCONTEST 2017<br>ref: A-000000-00371 |

**watt&sea**

AUTONOMY THANKS TO RENEWABLE ENERGY

15 rue de la Brigantine - 17000 La Rochelle - FRANCE  
tél +33(0)5 46 41 31 99 - contact@wattandsea.com - www.wattandsea.com  
SARL au capital de 231 400€ - Siret : 514 026 467 00019 - NAF : 7112B